

**BIPOLAR ANALOG INTEGRATED CIRCUIT**  
 **$\mu$ PC1891A****MATRIX SURROUND-SOUND PROCESSOR**

The  $\mu$ PC1891A is a specific IC to reproduce surround-sound by using a signal matrix.

The IC is based on a unique high-speed and low-noise bipolar process and high-precision on-chip filter technology, and provides ideal sound-field effects by using the minimum number of parts.

The IC provides wide sound with two speakers and rich, stereophonic sound with three speakers.

In the case of stereo signal, the IC has the movie mode to reproduce real human voices, the music mode to permit the listeners to experience the expanse of a music hall, and it has the monaural mode to make monaural signal into wide, deep sound. The modes can be selected freely by using 2-bit parallel control pins.

The package of the IC is a reliable, standard 20-pin DIP.

**FEATURES**

- Built-in high-precision filter
- Built-in output adjusting attenuator and mute circuit
- 2-bit parallel mode select
- Three modes are available: movie, music, and monaural modes
- Low power consumption: 12 V/20 mA TYP.

**APPLICATIONS**

- TV

**ORDERING INFORMATION**

Part Number	Package	Quality Grade
$\mu$ PC1891ACY	20-pin plastic DIP (400 mil)	Standard

Please refer to "Quality grade on NEC Semiconductor Devices" (Document number IEI-1209) published by NEC Corporation to know the specification of quality grade on the devices and its recommended applications.

The information in this document is subject to change without notice.

BLOCK DIAGRAM

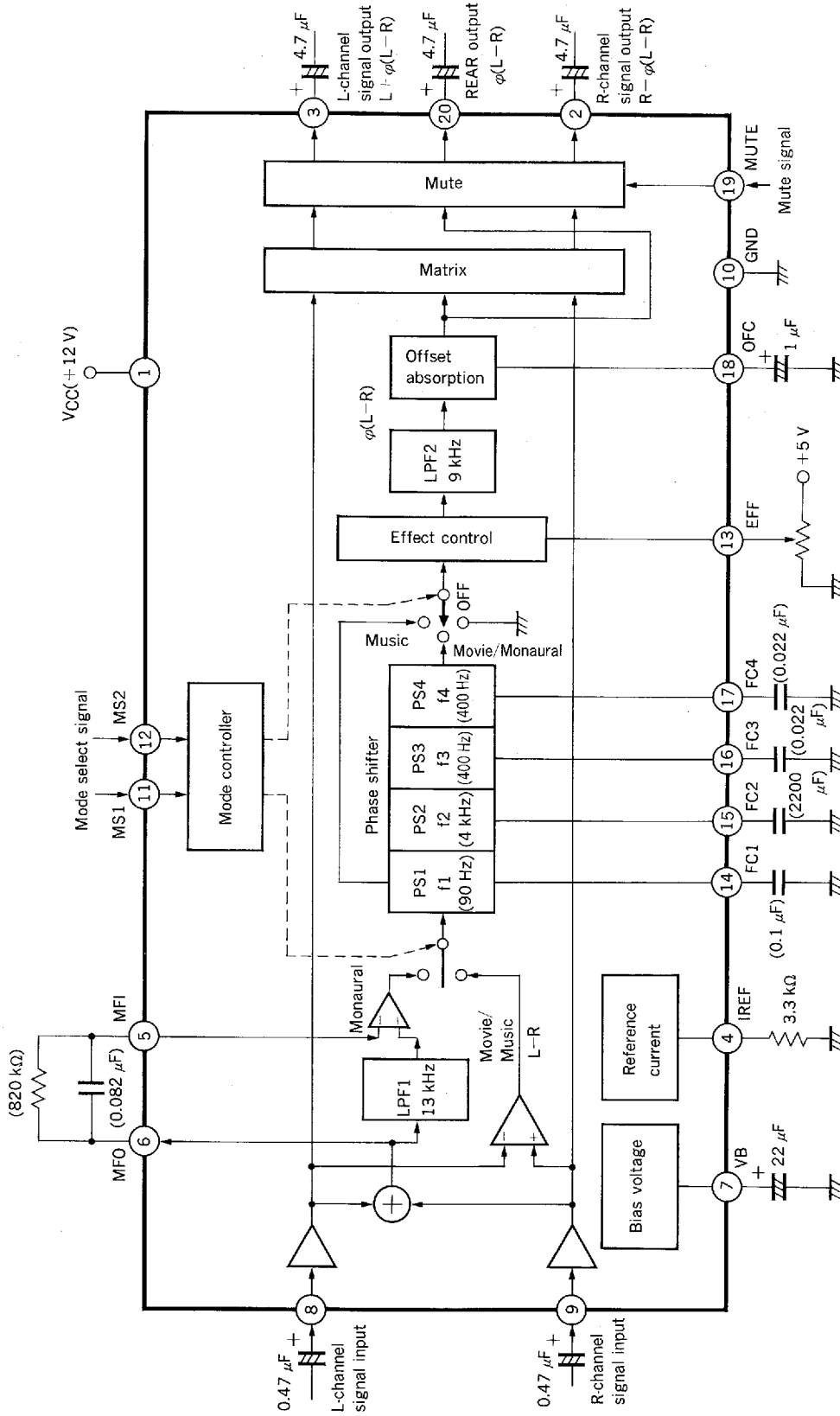

Note ( ) : Recommended value.

PIN CONFIGURATION (Top view)

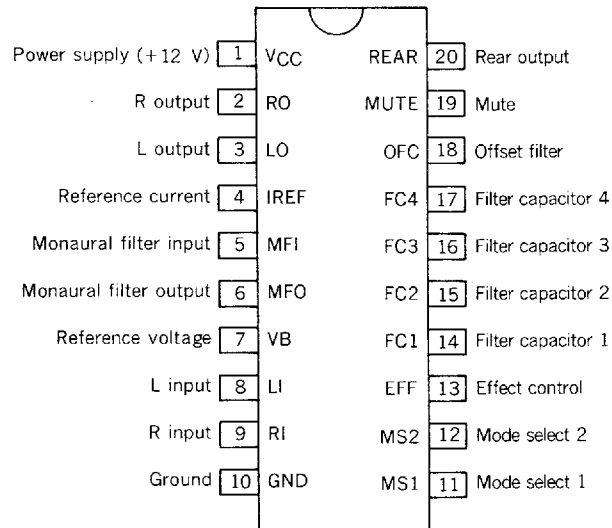

ABSOLUTE MAXIMUM RATINGS ( $T_a = 25\text{ }^\circ\text{C}$ )

ITEM	SYMBOL	RATING	UNIT	CONDITION
Supply Voltage	$V_{CC}$	+14	V	No signal
Input Pin Voltage	$V_{IN}$	$V_{CC}$	V	Voltage applied to pins 8, 9, 11, 12, 13, and 19
Output Pin Current	$I_{OUT}$	$\pm 10$	mA	Current to and from pins 2, 3, and 20
Storage Temperature	$T_{stg}$	-40 to +125	$^\circ\text{C}$	
Operating Temperature	$T_{opt}$	-20 to +75	$^\circ\text{C}$	$V_{CC} = 12\text{ V}$
Power Dissipation	$P_D$	600	mW	$T_a = 75\text{ }^\circ\text{C}$

RECOMMENDED OPERATING CONDITIONS

ITEM	SYMBOL	MIN.	TYP.	MAX.	UNIT	CONDITION
Supply Voltage (1) (Good Characteristic Range)	$V_{CC1}$	11	12	13	V	
Supply Voltage (2) (Surround Operating Range)	$V_{CC2}$	9		14	V	
Input Signal Amplitude	$V_{L1, R1}$		1.4	2.5	$V_{p-p}$	Signal voltage input to pins 8 and 9
Mode Select Pin Voltage (High)	$V_{MSH}$	4	5	$V_{CC}$	V	High voltage at pins 11 and 12
Mode Select Pin Voltage (Low)	$V_{MSL}$	0	0	2	V	Low voltage at pins 11 and 12
Mute Pin Voltage (High)	$V_{MVTEH}$	4	5	$V_{CC} - 3$	V	High voltage at pin 19
Mute Pin Voltage (Low)	$V_{MVTEL}$	0	0	2	V	Low voltage at pin 19
Effect Pin Voltage (High)	$V_{EFFH}$		5	$V_{CC} - 3$	V	Upper voltage at pin 13
Effect Pin Voltage (Low)	$V_{EFFL}$	-	0	-	V	Lower voltage at pin 13
Load Impedance	$Z_L$	10			$k\Omega$	Output from pins 2, 3, and 20
Ambient Operating Temperature	$T_{opt}$	-20		+75	$^\circ\text{C}$	

ELECTRICAL CHARACTERISTICS (T<sub>a</sub> = 25 °C, RH ≤ 70%, V<sub>CC</sub> = 12 V)

NO.	ITEM	SYMBOL	MIN.	TYP.	MAX.	UNIT	CONDITION	MEASURING CIRCUIT NO.
1	Supply Current	I <sub>CC</sub>		20	30	mA	No signal, I <sub>REF</sub> pin resistance: 3.3 kΩ	1
2	Bias Potential	V <sub>B</sub>	$\frac{V_{CC}-0.2}{2}$	$\frac{V_{CC}}{2}$	$\frac{V_{CC}+0.2}{2}$	V	Voltage at pin 7	2
3	Reference Current Pin Potential	V <sub>IR</sub>	1.10	1.20	1.30	V	I <sub>REF</sub> pin resistance: 3.3 kΩ	2
4	Mode Select Pin Current (1)	I <sub>MS1</sub>		110	160	μA	Voltage applied to pins 11 and 12: 12 V	3
5	Mode Select Pin Current (2)	I <sub>MS2</sub>		45	70	μA	Voltage applied to pins 11 and 12: 5 V	3
6	Mode Select Pin Current (3)	I <sub>MS3</sub>			12	μA	Voltage applied to pins 11 and 12: 0.8 V	3
7	Effect Control Pin Current	I <sub>EFF</sub>		0.3	1.0	μA	Voltage applied to pin 13: 0.0 to 5.0 V	4
8	Input Pin Voltage	V <sub>I</sub>	$\frac{V_{CC}-0.2}{2}$	$\frac{V_{CC}}{2}$	$\frac{V_{CC}+0.2}{2}$	V	Voltage applied to pins 8 and 9	2
9	Output Pin Voltage	V <sub>OUT</sub>	4.6	5.1	5.6	V	Voltage applied to pins 2, 3, and 20	2
10	In-phase Gain (OFF)	G <sub>OFF</sub>	-0.2	0.8	1.8	dB	Mode OFF, Input signal of 1 kHz, 1.4 V <sub>p-p</sub> , Rin → Rout, Lin → Lout	5
11	LR In-phase Gain Difference (OFF)	DG <sub>OFF</sub>	-1	0	+1	dB	Mode OFF, input signal of 1 kHz, 1.4 V <sub>p-p</sub> (Rin → Rout) - (Lin → Lout)	5
12	In-phase Gain (Movie 1)	G <sub>MOV1</sub>	2	7	12	dB	Movie mode, V <sub>EFF</sub> = 2.5 V Input signal of 1 kHz, 1.4 V <sub>p-p</sub> Rin → Rout, Lin → Lout	5
13	In-phase Gain (Movie 2)	G <sub>MOV2</sub>	3	8	13	dB	Movie mode, V <sub>EFF</sub> = 5.0 V Input signal of 1 kHz, 1.4 V <sub>p-p</sub> Rin → Rout, Lin → Lout	5
14	LR In-phase Gain Difference (Movie)	DG <sub>MOV</sub>	-2	0	+2	dB	Movie mode, V <sub>EFF</sub> = 5.0 V Input signal of 1 kHz, 1.4 V <sub>p-p</sub> (Rin → Rout) - (Lin → Lout)	5
15	In-phase Gain (Music 1)	G <sub>MUS1</sub>	4	6	8	dB	Music mode, V <sub>EFF</sub> = 2.5 V Input signal of 1 kHz, 1.4 V <sub>p-p</sub> Rin → Rout, Lin → Lout	5
16	In-phase Gain (Music 2)	G <sub>MUS2</sub>	5.5	7.5	9.5	dB	Music mode, V <sub>EFF</sub> = 5.0 V Input signal of 1 kHz, 1.4 V <sub>p-p</sub> Rin → Rout, Lin → Lout	5
17	LR In-phase Gain Difference (Music)	DG <sub>MUS</sub>	-2	0	+2	dB	Music mode, V <sub>EFF</sub> = 2.5 V Input signal of 1 kHz, 1.4 V <sub>p-p</sub> (Rin → Rout) - (Lin → Lout)	5
18	Monaural L Output 1	L <sub>MON1</sub>	2.5	4.5	6.5	dB	Monaural mode, V <sub>EFF</sub> = 2.5 V Input signal of 250 Hz 1.4 V <sub>p-p</sub> , Rin and Lin → Lout	5
19	Monaural L Output 2	L <sub>NON2</sub>		-4.0	0.0	dB	Monaural mode, V <sub>EFF</sub> = 2.5 V Input signal of 1 kHz, 1.4 V <sub>p-p</sub> , Rin and Lin → Lout	5
20	Monaural L Output 3	L <sub>MON3</sub>	4.5	7.0	9.5	dB	Monaural mode, V <sub>EFF</sub> = 2.5 V Input signal of 3.6 kHz, 1.4 V <sub>p-p</sub> , Rin and Lin → Lout	5

NO.	ITEM	SYMBOL	MIN.	TYP.	MAX.	UNIT	CONDITION	MEASURING CIRCUIT NO.
21	Monaural R Output 1	RMON1		-4.5	0.0	dB	Monaural mode, $V_{EFF} = 2.5\text{ V}$ Input signal of 250 Hz, 1.4 $V_{p-p}$ , Rin and Lin → Rout	5
22	Monaural R Output 2	RMON2	1.8	3.8	5.8	dB	Monaural mode, $V_{EFF} = 2.5\text{ V}$ Input signal of 1 kHz, 1.4 $V_{p-p}$ , Rin and Lin → Rout	5
23	Monaural R Output 3	RMON3		-20	-8	dB	Monaural mode, $V_{EFF} = 2.5\text{ V}$ Input signal of 3.6 kHz, 1.4 $V_{p-p}$ , Rin and Lin → Rout	5
24	Rear Output Gain 1	GREA1		-30		dB	Music mode, $V_{EFF} = 0.0\text{ V}$ Input signal of 1 kHz, 1.4 $V_{p-p}$ , Rin or Lin → REARout	6
25	Rear Output Gain 2	GREA2	-12	-9.4	-8.0	dB	Music mode, $V_{EFF} = 2.5\text{ V}$ Input signal of 1 kHz, 1.4 $V_{p-p}$ , Rin or Lin → REARout	6
26	Rear Output Gain 3	GREA3		-8.2	-5.0	dB	Music mode, $V_{EFF} = 5\text{ V}$ Input signal of 1 kHz, 1.4 $V_{p-p}$ , Rin or Lin → Lout	6
27	Maximum Output	VOM1	7.8	8.2		$V_{p-p}$	Mode OFF, $V_{CC} = 12\text{ V}$ , Input signal of 1 kHz T.H.D. = 3 %, Rout and Lout measurement	7
28	Distortion Factor	T.H.D.		0.1	0.5	%	Mode OFF, Input signal of 1 kHz, 1.4 $V_{p-p}$ , Rin → Rout, Lin → Lout	7
29	Output Noise (OFF)	NO(OFF)		0.2	0.4	$mV_{r.m.s.}$	Mode OFF, Input termination Using DIN/AUDIO, Rout and Lout measurement	8
30	Output Noise (Movie)	NO(MOV)		0.2	0.4	$mV_{r.m.s.}$	Movie mode, Input termination Using DIN/AUDIO, Rout and Lout measurement	8
31	Output Noise (Music)	NO(MUS)		0.2	0.4	$mV_{r.m.s.}$	Music mode, Input termination Using DIN/AUDIO, Rout and Lout measurement	8
32	Output Noise (Monaural)	NO(MON)		0.2	0.4	$mV_{r.m.s.}$	Monaural mode, Input termination Using DIN/AUDIO, Rout and Lout measurement	8
33	Mute Attenuation	DM		-80	-70	dB	Mode OFF, $V_{EFF} = 2.5\text{ V}$ , $V_{MUTE} = 5\text{ V}$ Input signal of 4 kHz, 1.4 $V_{p-p}$ , Rin → Rout, Lin → Lout	9
34	Crosstalk	S <sub>x</sub>		-60	-50	dB	Mode OFF, $V_{EFF} = 2.5\text{ V}$ Input signal of 4 kHz, 1.4 $V_{p-p}$ , Rin → Lout, Lin → Rout	9
35	Inter-mode Offset	VOSM	-150	0	150	mV	Difference among values in each modes. Rout, Lout and REARout	10
36	Mute offset	VOSD	-150	0	150	mV	Difference between mute-on/ off values Rout, Lout, and REARout measurement	10
37	Signal Input Pin Impedance	Z <sub>IN</sub>	20	40		kΩ	Rin and Lin measurement	11
38	Output Pin Impedance	Z <sub>OUT</sub>		20	60	Ω	Rout, Lout, and REARout measurement	

Note: Rin : pin 9  
 Lin : pin 8  
 Rout : pin 2  
 Lout : pin 3  
 REARout : pin 20

Measuring Circuit 1

Power supply Current ( $I_{CC}$ )

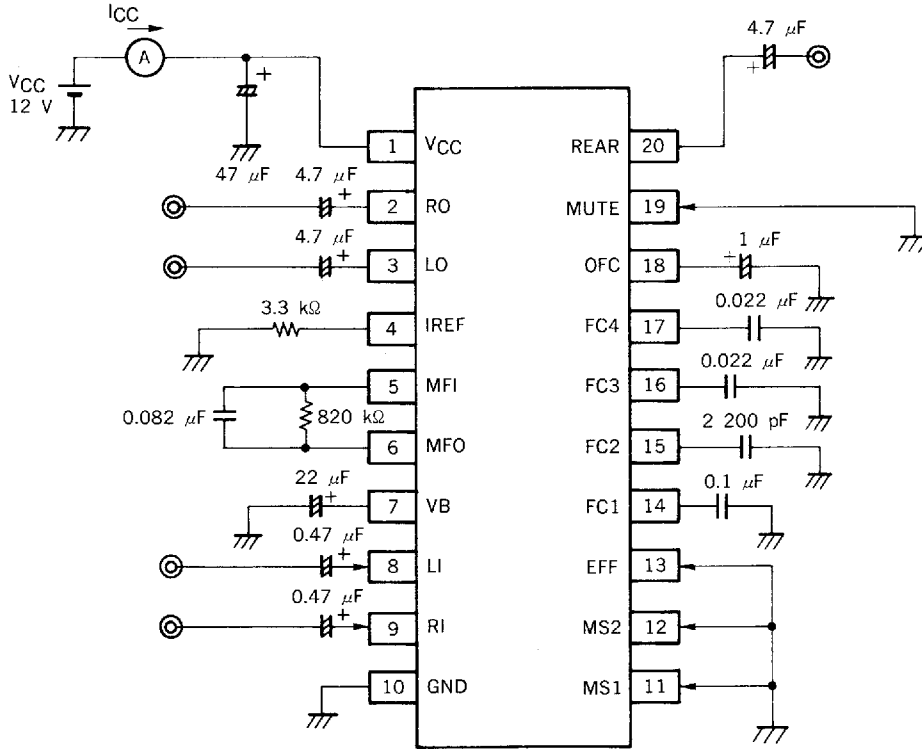

Measuring Circuit 2

Bias potential input/output pin potential and reference current pin potential

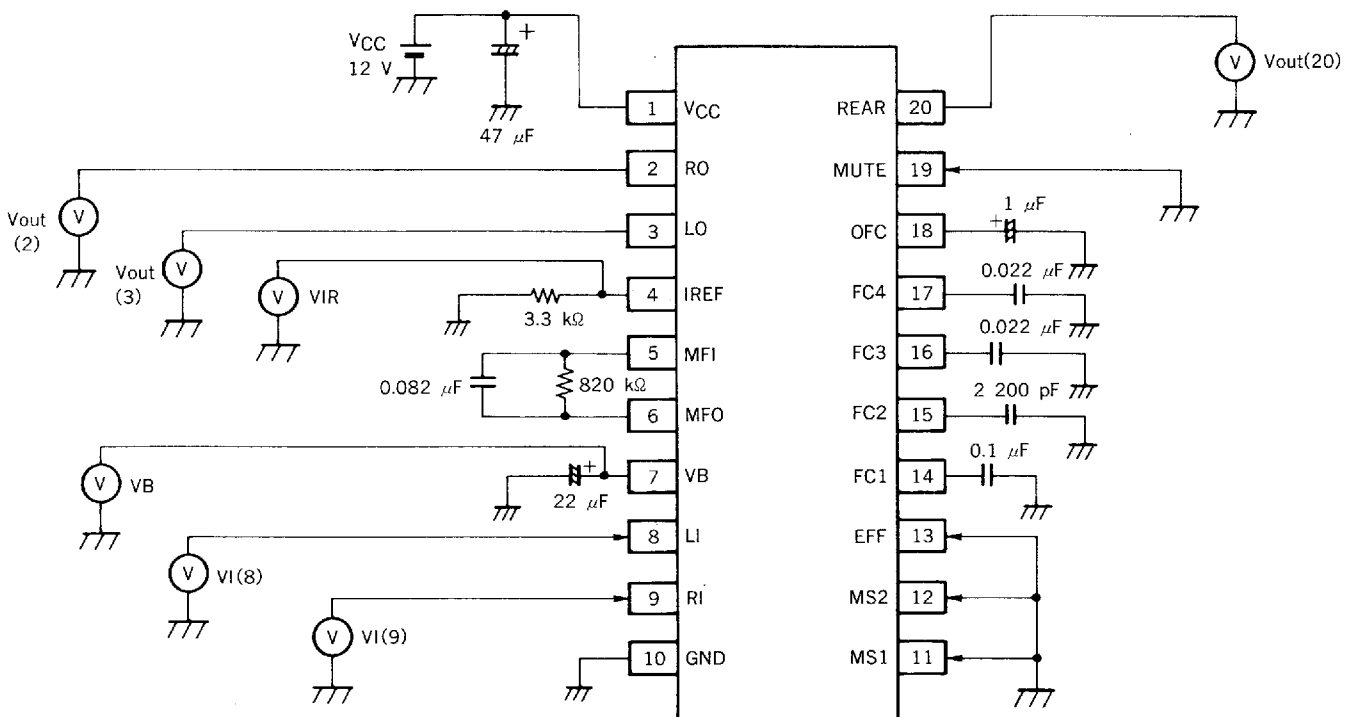

Measuring Circuit 3

Mode select pin current ( $I_{MS}$ )

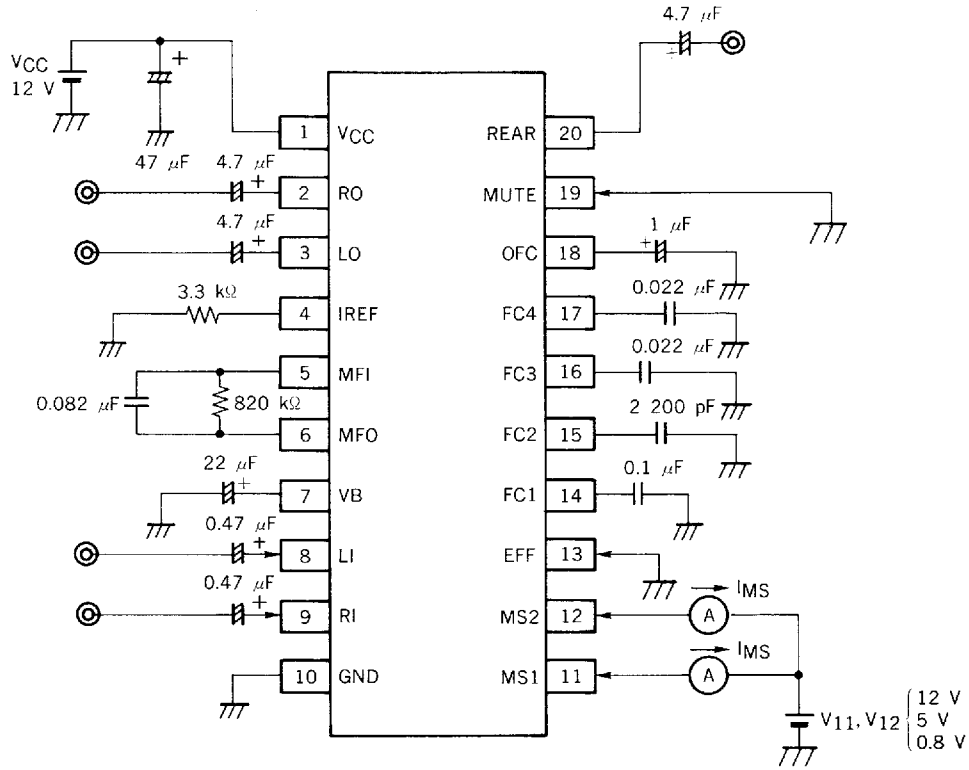

Measuring Circuit 4

Effect control pin current ( $I_{EFF}$ )

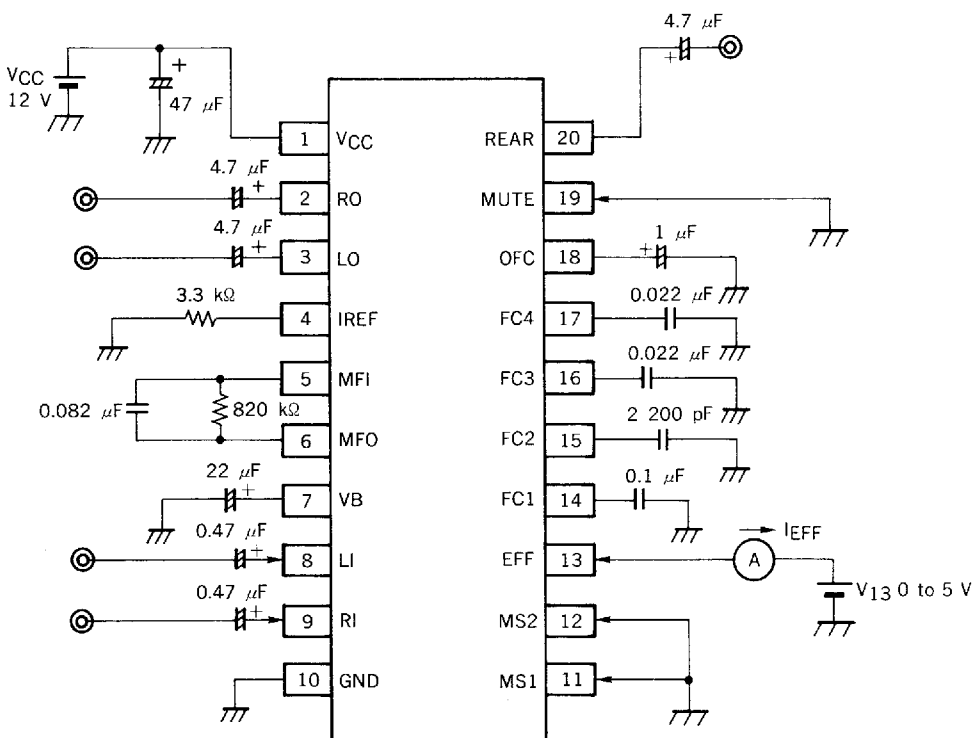

Measuring Circuit 5

In-phase gain and monaural output

$$\text{Gain} = 20 \log \left( \frac{V_{\text{out}}}{V_{\text{in}}} \right)$$

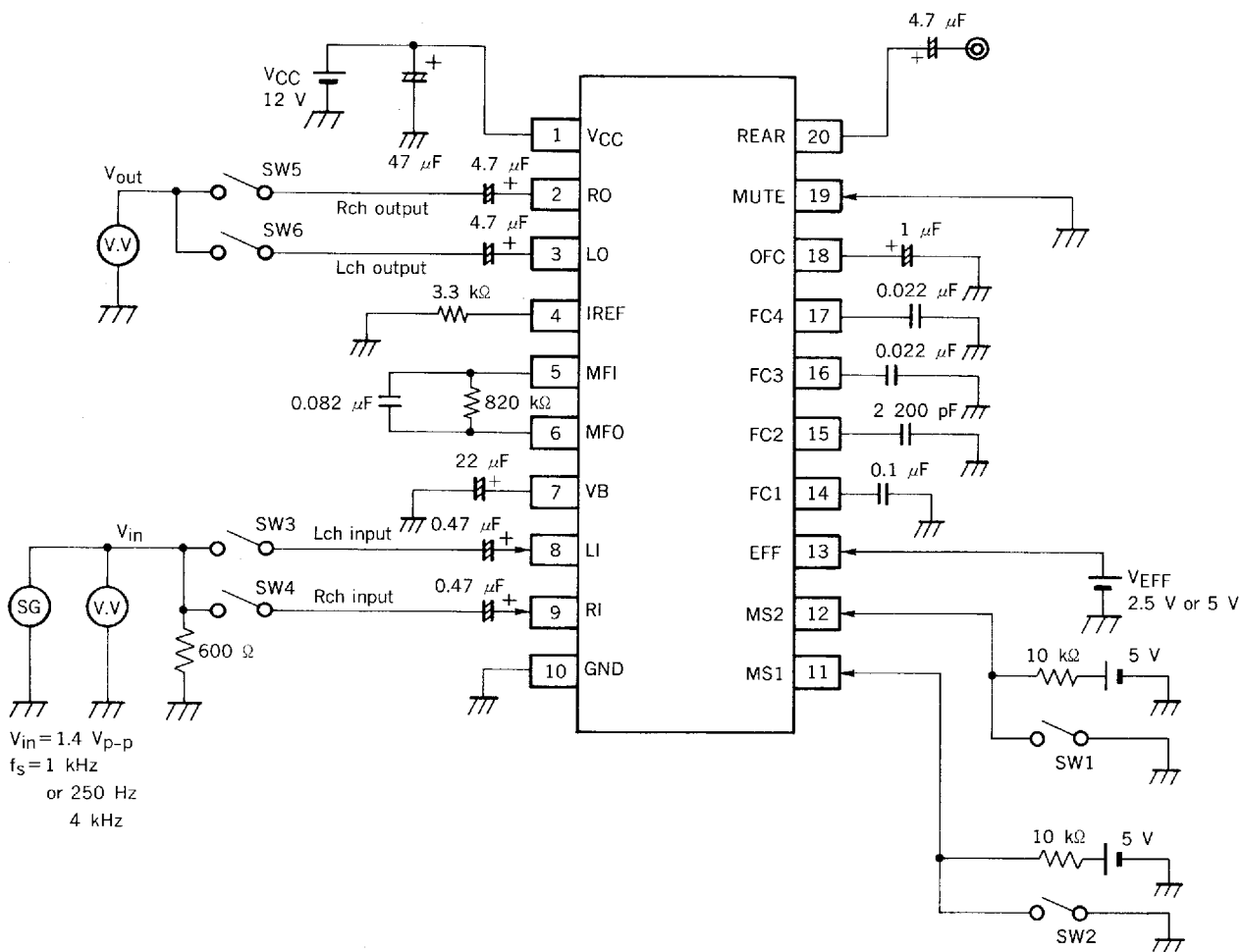

$V_{in} = 1.4 \text{ V}_{p-p}$   
 $f_s = 1 \text{ kHz}$   
 or 250 Hz  
 4 kHz

Mode Select

Item	Input	Output	SW3	SW4	SW5	SW6
In-phase gain Mode: Off Music Movie	Lin	Lout	ON	OFF	OFF	ON
	Rin	Rout	OFF	ON	ON	OFF
	Lin and Rin	Lout	ON	ON	OFF	ON
Monaural output	Lin and Rin	Rout	ON	ON	ON	OFF

Mode	SW1	SW2
OFF	ON	ON
Music	ON	OFF
Movie	OFF	ON
Monaural	OFF	OFF



Measuring Circuit 6

Rear output gain (G<sub>REA</sub>)

$$\text{Gain} = 20 \log \left( \frac{V_{\text{out}}}{V_{\text{in}}} \right)$$

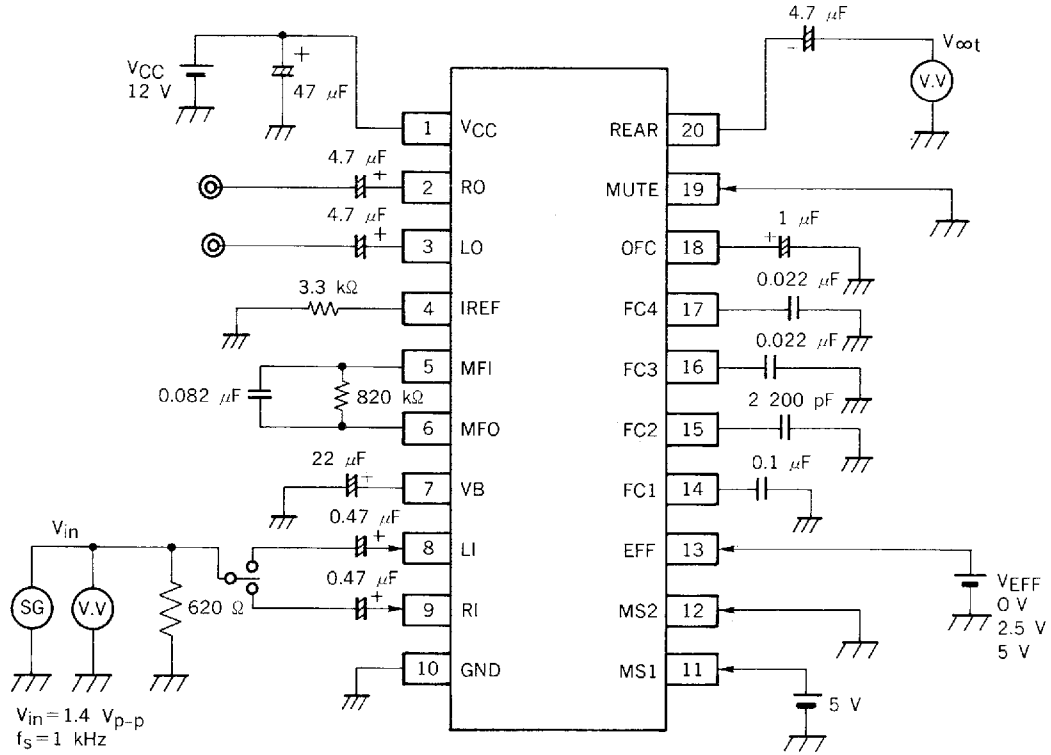

Measuring Circuit 7

Maximum output and distortion factor (V<sub>OM</sub>, T.H.D.)

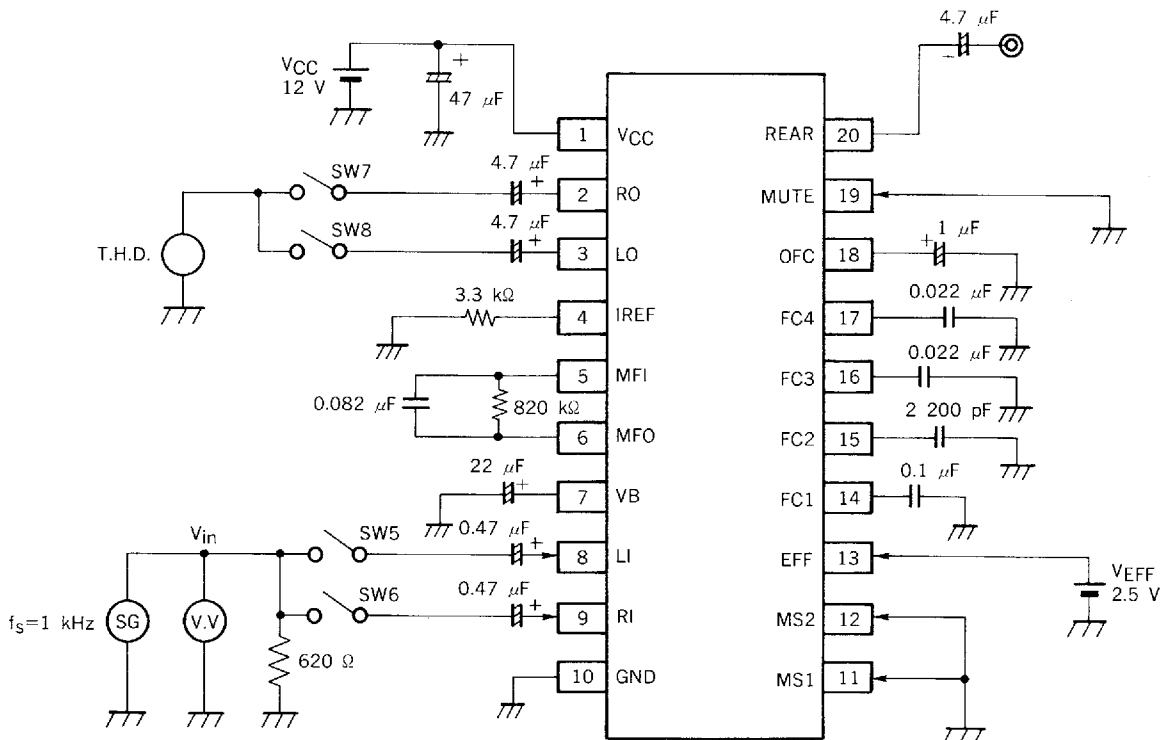

Measuring Circuit 8

Output noise ( $N_O$ )

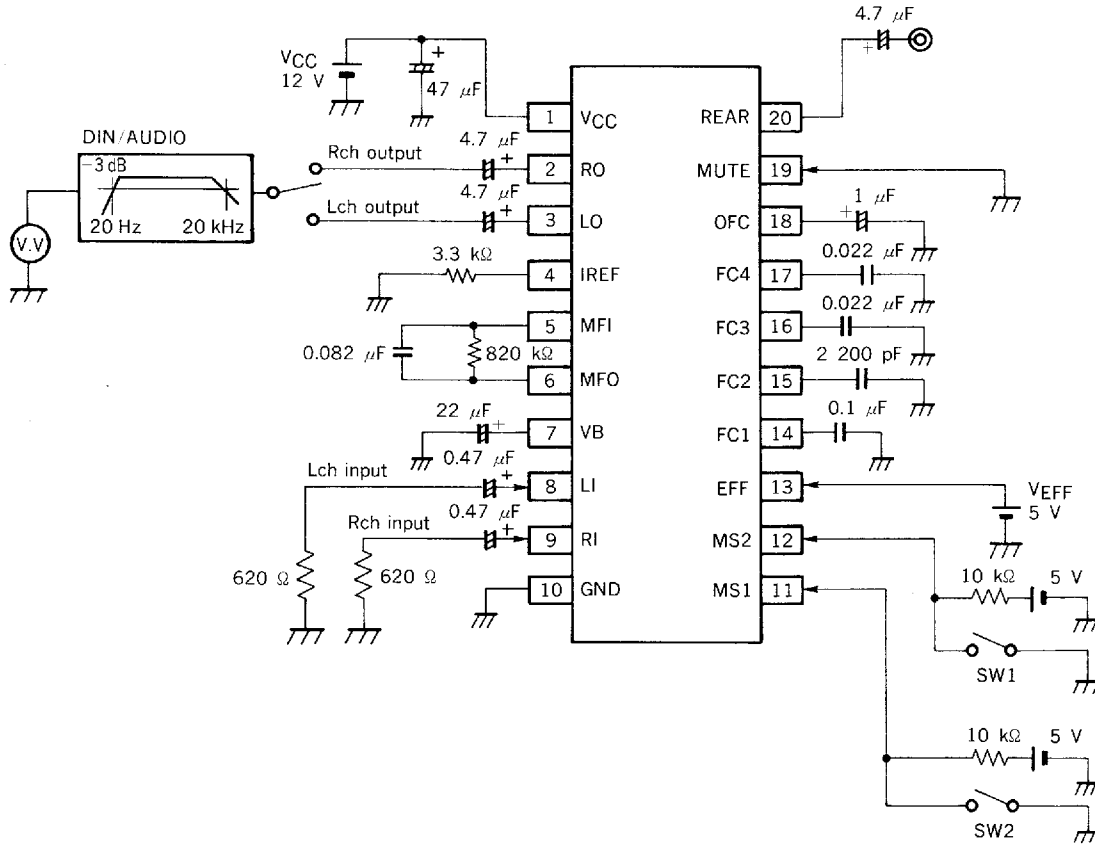

Mode select

Mode	SW1	SW2
OFF	ON	ON
Music	ON	OFF
Movie	OFF	ON
Monaural	OFF	OFF

Measuring Circuit 9

Mute attenuation (DM) and crosstalk (SX)

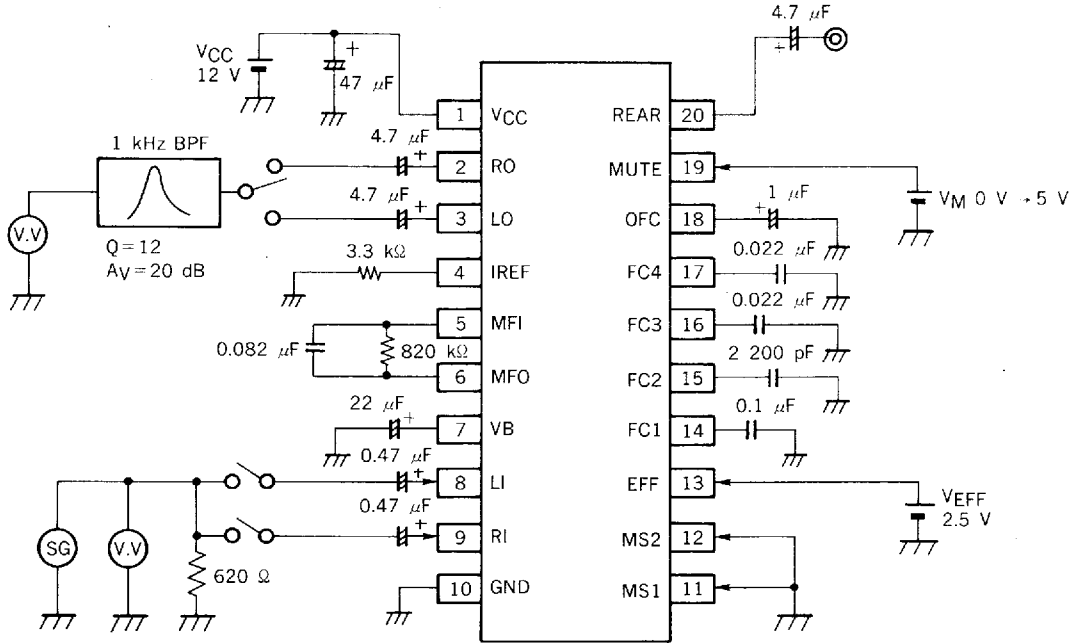

Measuring Circuit 10

Inter-mode and mute offsets

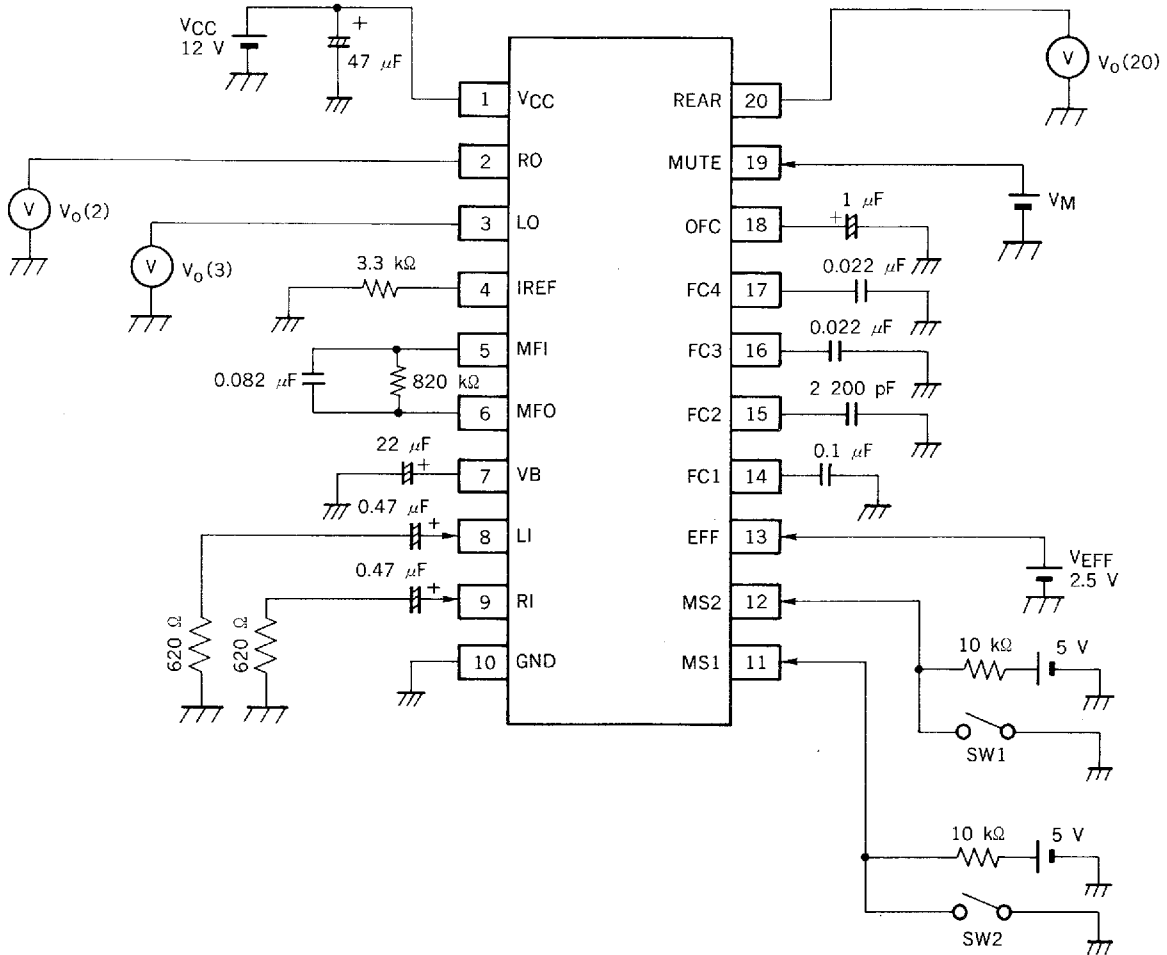

- Inter-mode offset ( $V_{OSM}$ )  
Between  $V_o$  (in each mode) and  $V_o$  (in OFF mode)  
(Note:  $V_M = 0\text{ V}$ )
- Mute offset ( $V_{OSD}$ )  
Between  $V_o$  ( $V_M = 0\text{ V}$ ) and  $V_o$  ( $V_M = 5\text{ V}$ )  
(Note: Mode OFF)

Mode Select

Mode	SW1	SW2
OFF	ON	ON
Music	ON	OFF
Movie	OFF	ON
Monaural	OFF	OFF

Measuring Circuit 11

Signal input pin impedance ( $Z_{in}$ )

$$Z_{in} = \frac{V_{in}}{I_{in}}$$

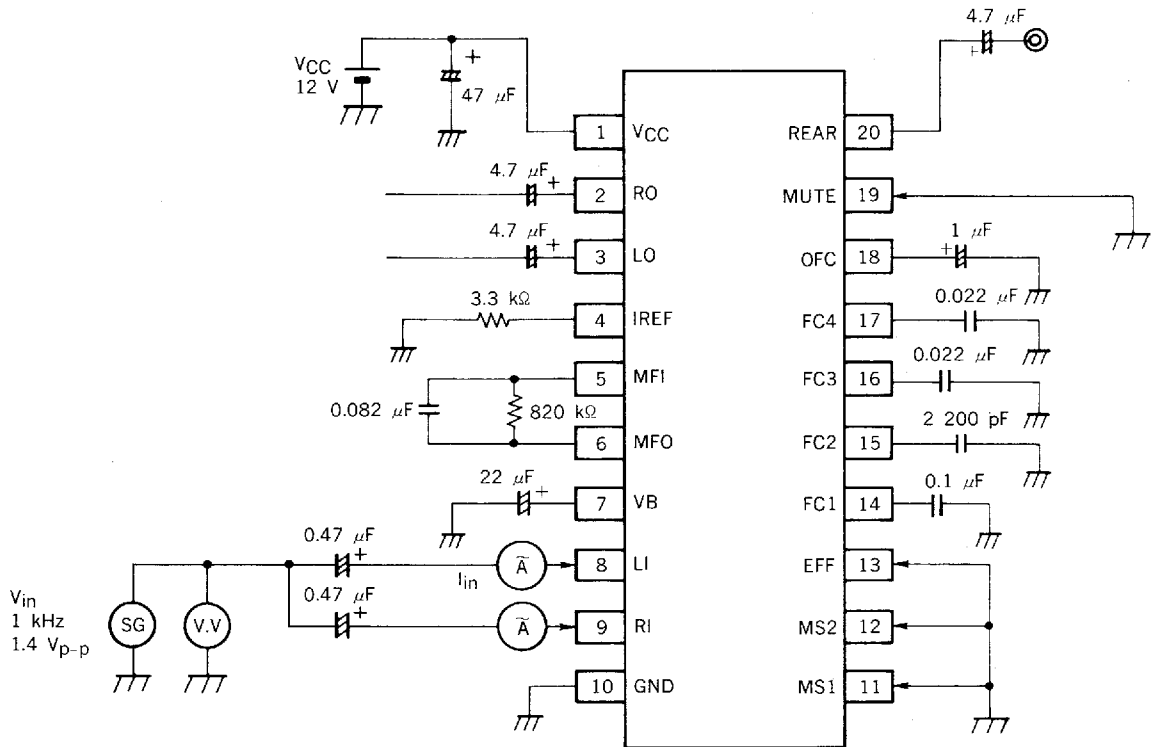

Mode Control

The μPC1891A allows four types of surround effects in the movie, music, monaural and OFF modes to be selected according to their respective combinations of H and L levels of pins No. 11 (MS1) and No. 12 (MS2).

Mode Select Code

Code Mode	MS1 (11)	MS2 (12)
OFF	L	L
Music	H	L
Movie	L	H
Monaural	H	H

**Caution** In the case of changing surround mode and power ON/OFF, mute (approx. 200 ms) must be used for pop noise reduction.

The following shows reference data for frequency response characteristics in each mode. It will help explain each type of surround effect. For the characteristics of the IC, please see the list of electrical characteristics.

Frequency Response Characteristics in Each Mode ( $T_a = 25^\circ\text{C}$ )

1. OFF Mode (Lch, Rch)

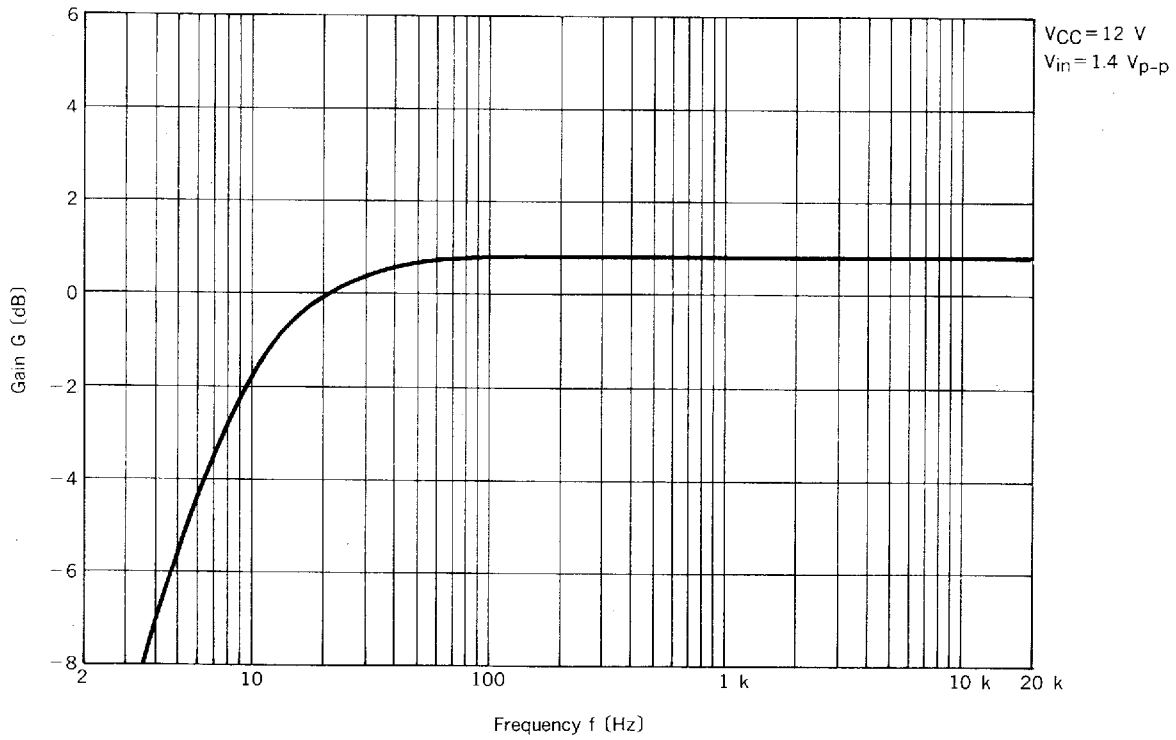

★ 2. Movie Mode (Lch)

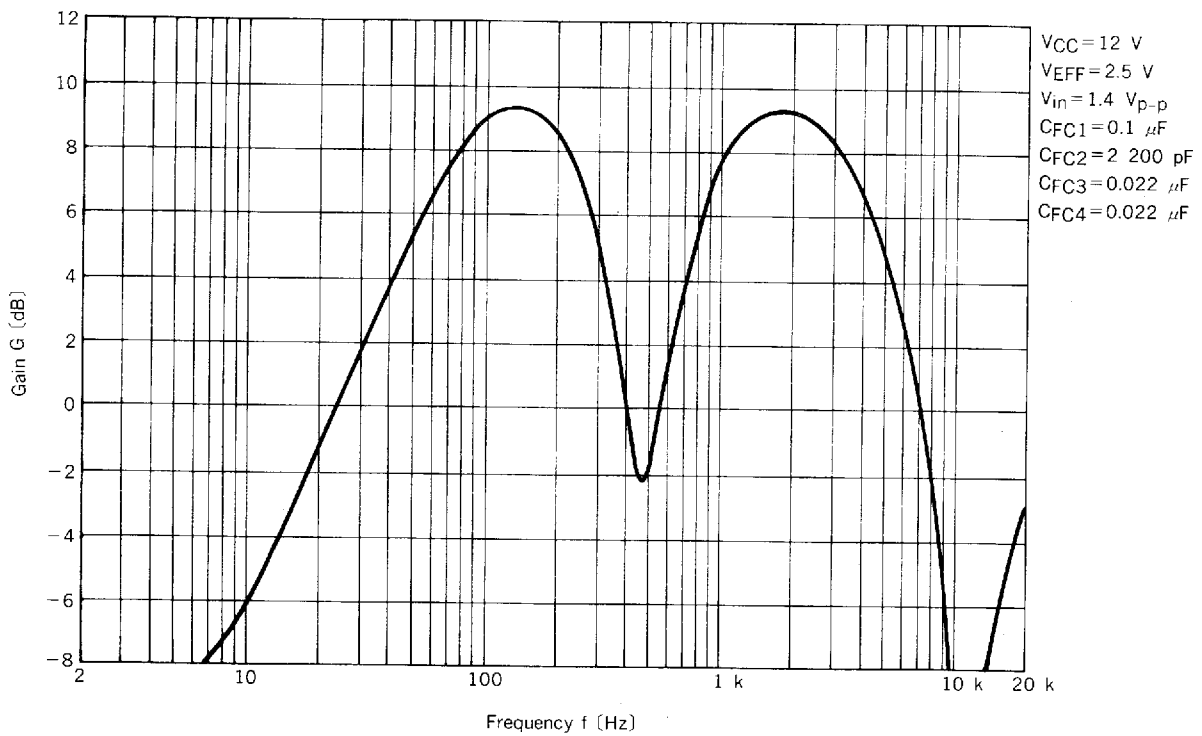

3. Movie Mode (Rch)

★

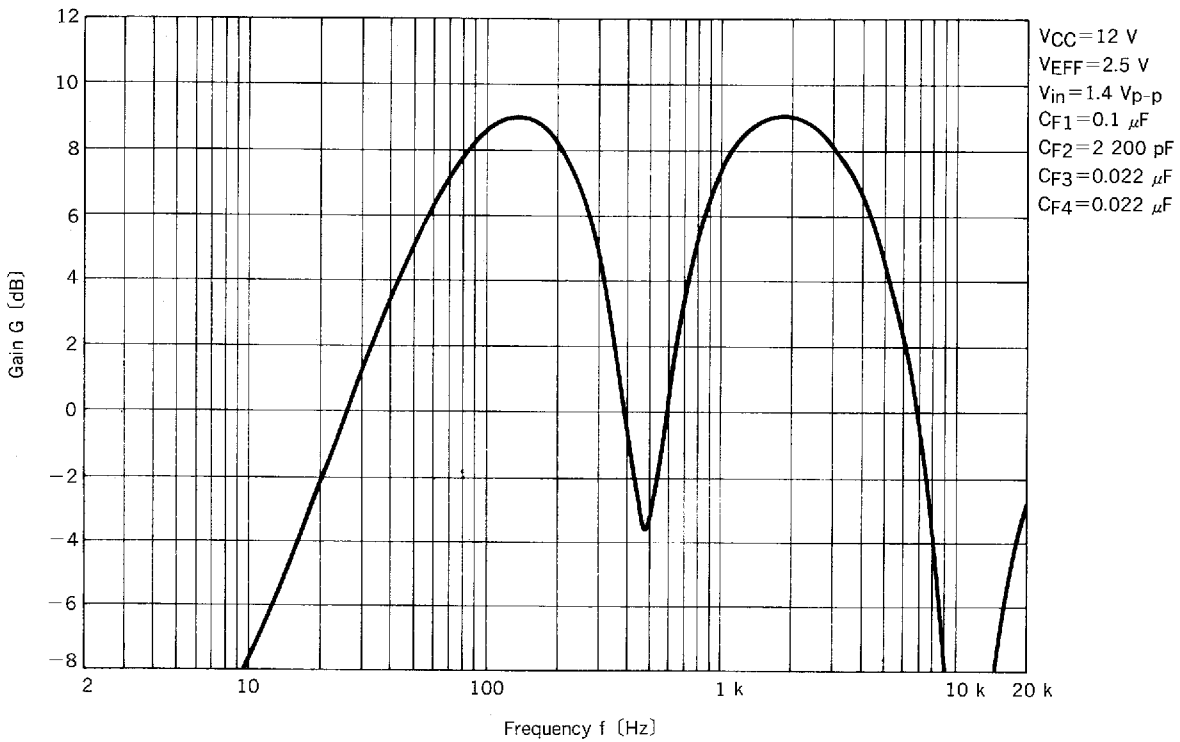

4. Music Mode (Lch)

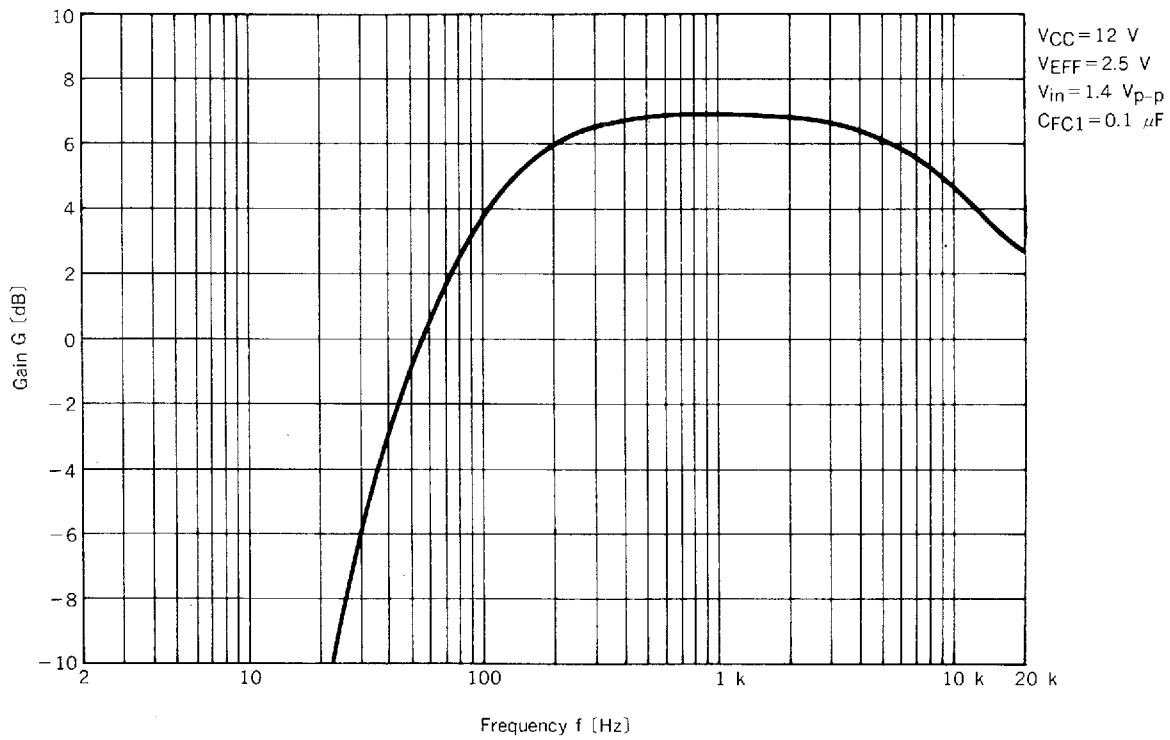

5. Music Mode (Rch)

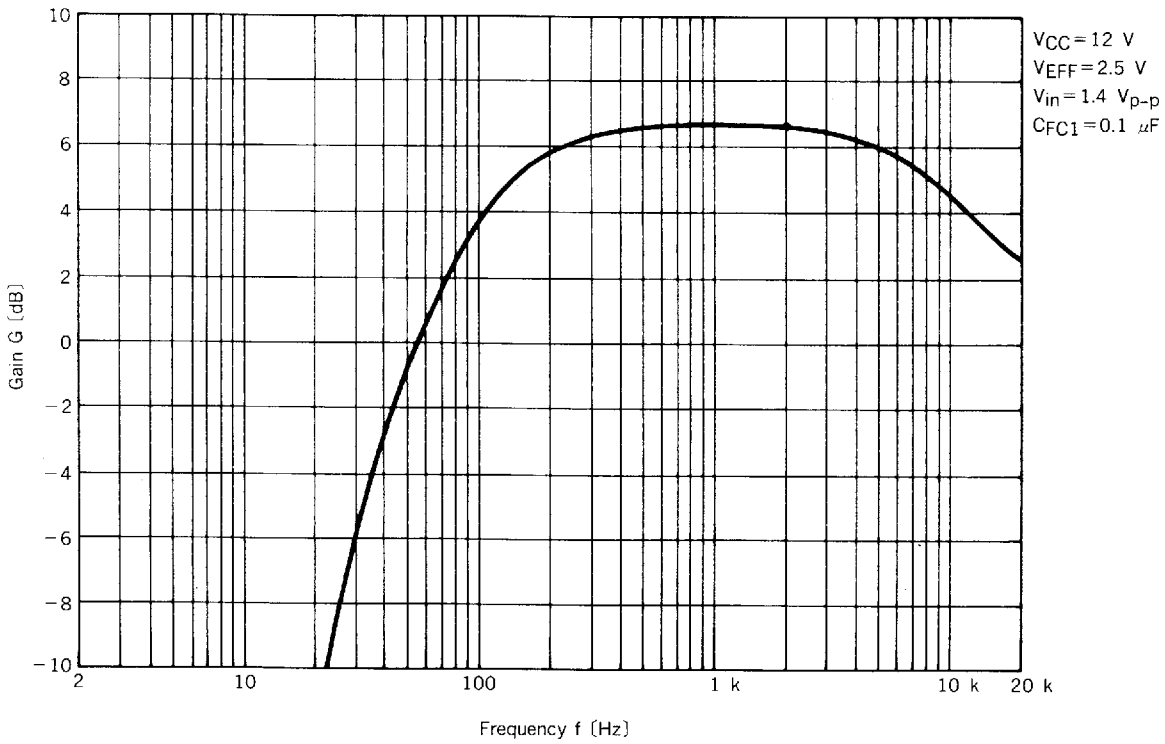

6. Monaural Mode (Lch)

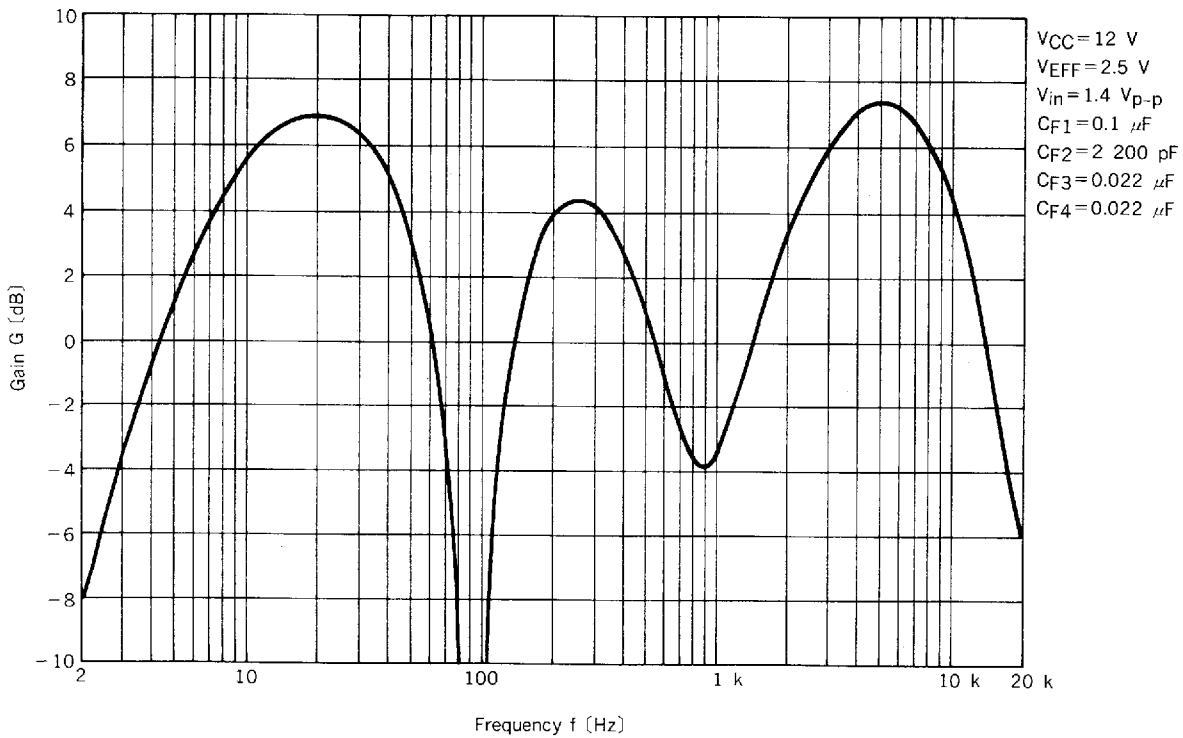



7. Monaural Mode (Rch)

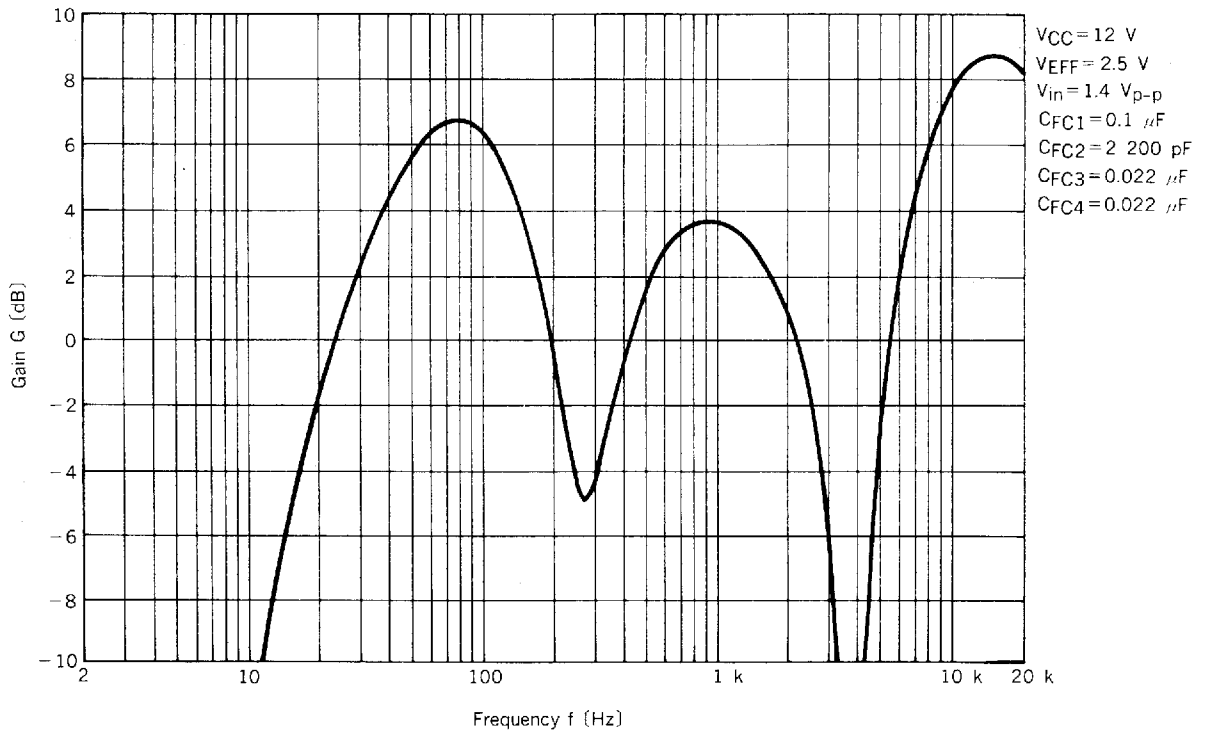

★ Gain and Phase Characteristics of Phase Shifter ( $T_a = 25^\circ\text{C}$ )

1. Movie Mode

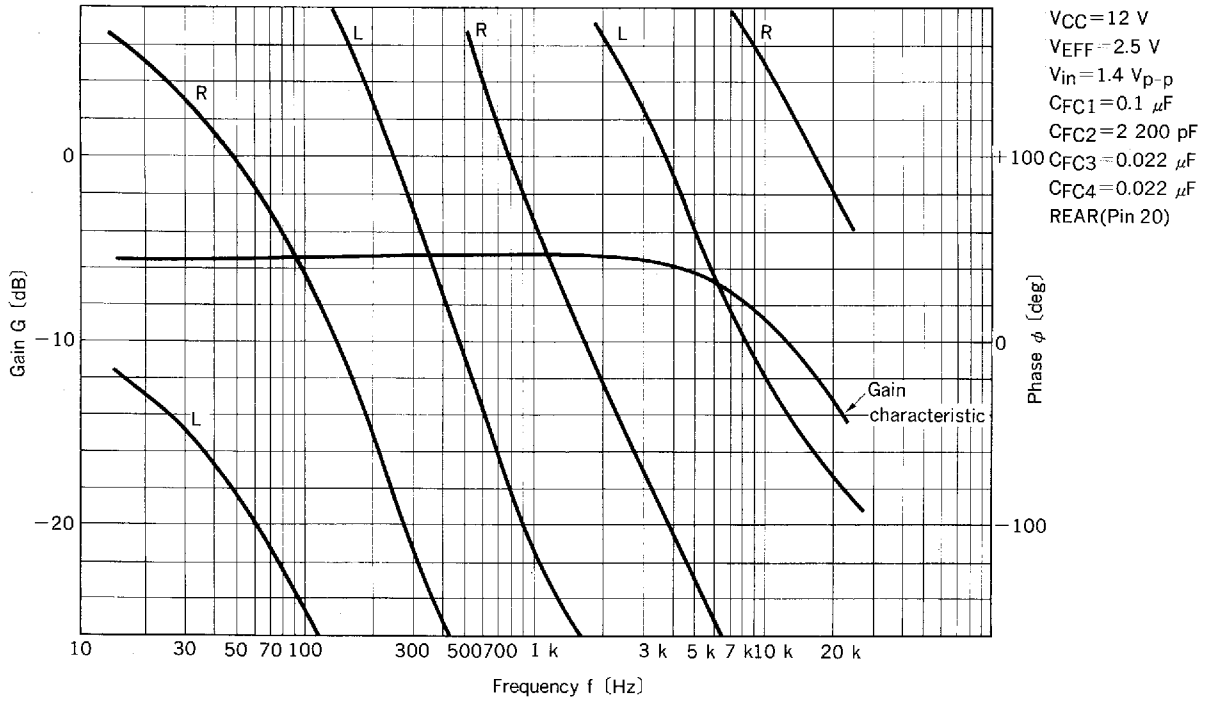

2. Music Mode

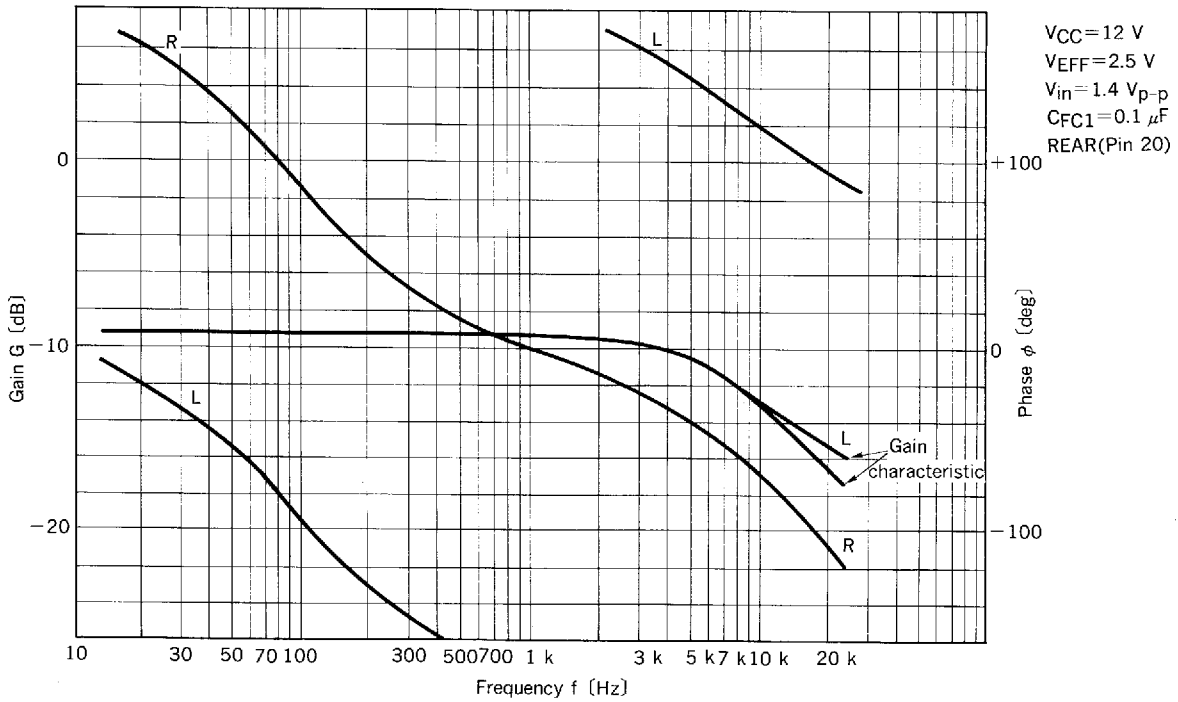

3. Monaural Mode

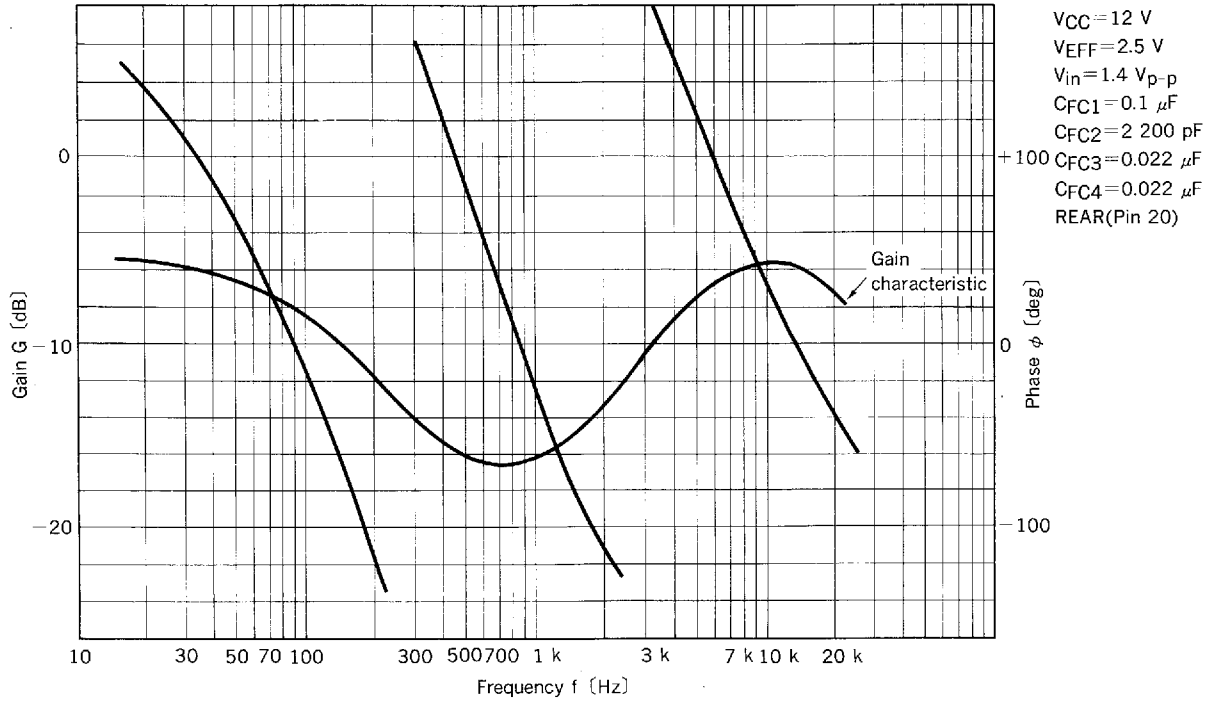

★ Change of Frequency Characteristics Depending on External Parts

1. Setting of each phase shifter (pin 14, 15, 16, 17)

Change capacitance of external capacitors (pin 14, 15, 16, 17) on setting amount of phase shift of each phase shifter.

Pole frequency of each phase shifter can be set because the pole frequency is in inverse proportion to the capacitance of external capacitors. The amount of phase shift of each phase shifter is set by this pole frequency.

$$f_0 \propto 1/C$$

$f_0$ : Pole frequency

C : Value of external capacitor

Phase shifter	Pin number	External Capacitor (Recommended value)	Pole frequency (Recommended value)	Setting range
PS1	14	0.1 μF	90 Hz	90 Hz ± 10 %
PS2	15	2200 pF	4 kHz	4 kHz ± 10 %
PS3	16	0.022 μF	400 Hz	400 Hz ± 10 %
PS4	17			

2. Setting of HPF (High-pass filter) for monaural and surround signal (pin 5, 6)

Set the HPF for monaural and surround signal by changing the value of external capacitor and resistor connected to pins 5 and 6.

$$f_c = \frac{1}{2\pi C(R/Z)}$$

$f_c$ : Cut-off frequency

C : Value of external capacitor

R : Value of external resistor

Z : Input impedance of pin 5 (61 kΩ ± 20 %)

Effect Adjustment Characteristic

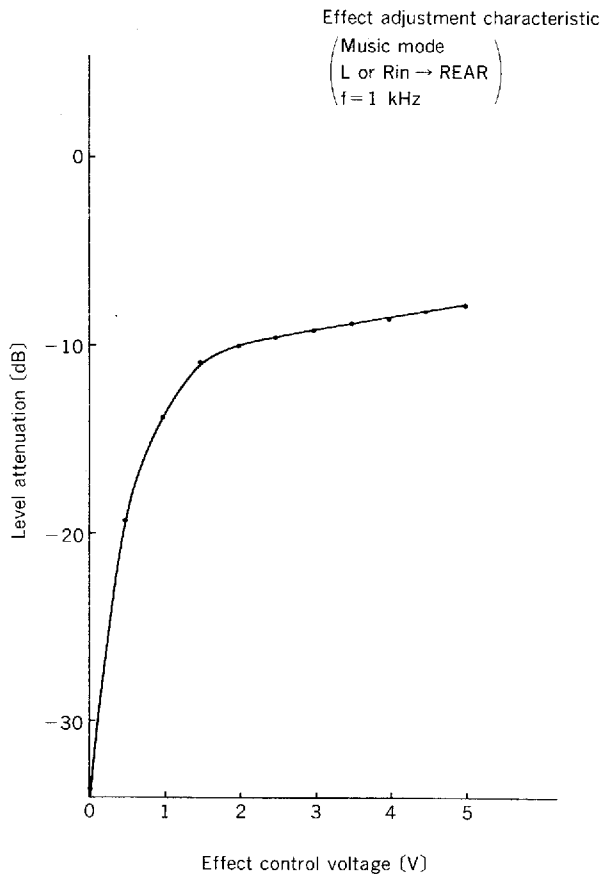

Mute Control Characteristic

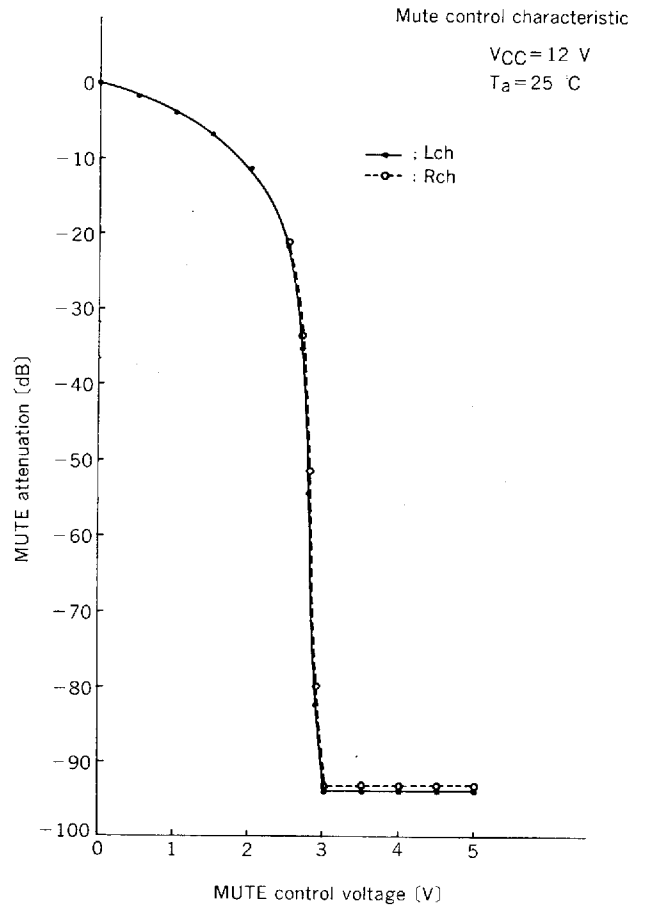

Pin Function

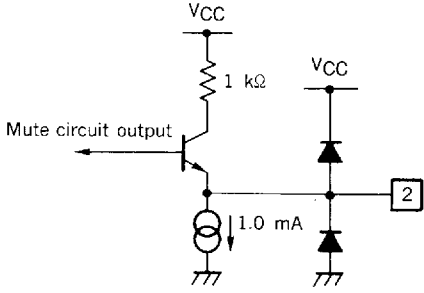
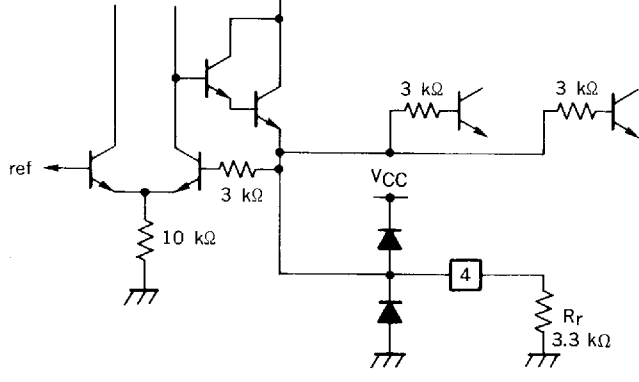
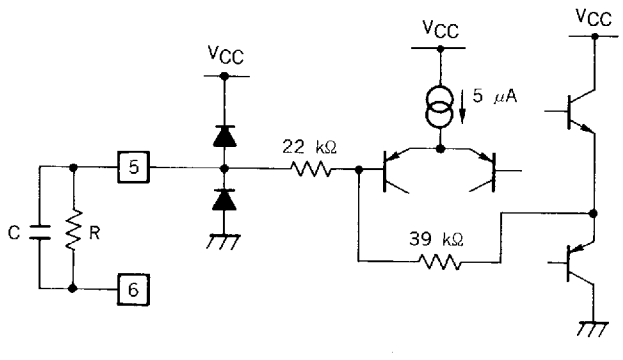
PIN NO.	EQUIVALENT CIRCUIT	FUNCTION
<p>1 (12.0 V)</p>	<p>VCC</p>	<p>Power Supply pin</p>
<p>2 3 20 (5.2 V)</p>		<p>Pin 2 : Rch output pin Pin 3 : Lch output pin Pin 20 : Rear channel output pin DC voltage of these pins : <math>\frac{1}{2} V_{CC} - V_{BE}</math></p>
<p>4 (1.2 V)</p>		<p>Adjuster pin to determine the time constant (frequency response characteristic in surround mode) of the phase shifter. Set the current flowing from pin 4. Note: <math>R_r</math> must be 3.3 kΩ.</p>
<p>5 (6.0 V)</p>		<p>Pin for HPF in the monaural mode. Insert CR between pins 5 and 6. Time constant <math>f_c</math>: <math>f_c = 1/2\pi C \times (R/Z)</math> Z is the input impedance of pin 5: about 61 kΩ.</p>

PIN NO.	EQUIVALENT CIRCUIT	FUNCTION
<p>6 (6.0 V)</p>		<p>Pin for HPF in the monaural mode like the case of pin 5.</p>
<p>7 (6.0 V)</p>		<p>The pin to connect the power supply ripple filter and has: Operating point bias: 1/2 V<sub>CC</sub>. Impedance: About 10 kΩ.</p>
<p>8 9 (6.0 V)</p>		<p>Pin 8 : Lch input pin Pin 9 : Rch input pin The input impedance is about 40 kΩ.</p>
<p>10 (0.0 V)</p>	<p>GND</p>	<p>Pin for ground of device</p>

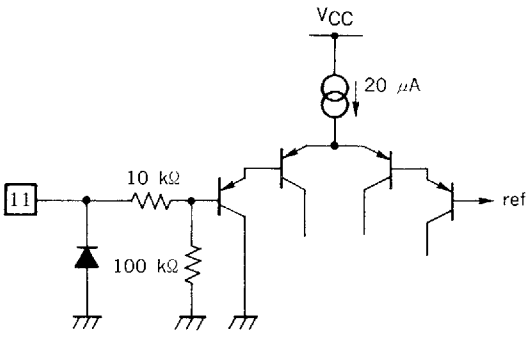
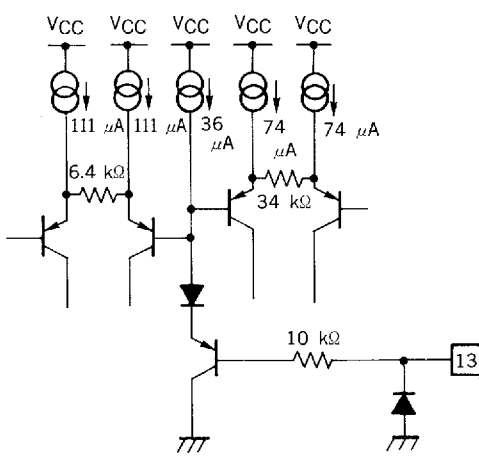
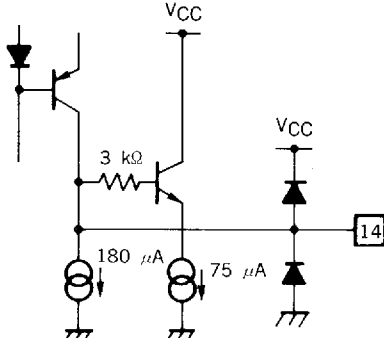
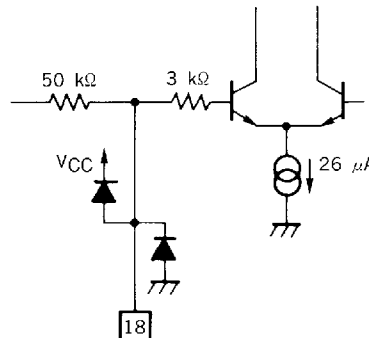
PIN NO.	EQUIVALENT CIRCUIT	FUNCTION
<p>11 12</p>		<p>The pins select one of the surround modes. (Two-bit parallel control by pins 11 and 12) The input impedance of each pin is about 110 kΩ. The pin becomes low when it is opened.</p>
<p>13</p>		<p>Pin for surround effect adjustment.</p>
<p>14 15 16 17 (6.7 V)</p>		<p>Capacitor connection pin to determine the time constant of the phase shifter. Pin 14 is for music surround-sound. Pins 14 to 17 are for movie and monaural surround sound. DC voltage of these pins : <math>\frac{1}{2} V_{CC} + V_{BE}</math></p>
<p>18 (6.0 V)</p>		<p>Matrix circuit DC offset absorption pin. The pin absorbs the offset generated from the phase shifter.</p>



PIN NO.	EQUIVALENT CIRCUIT	FUNCTION
19		Pin for mute circuit control.

20PIN PLASTIC DIP (400 mil)

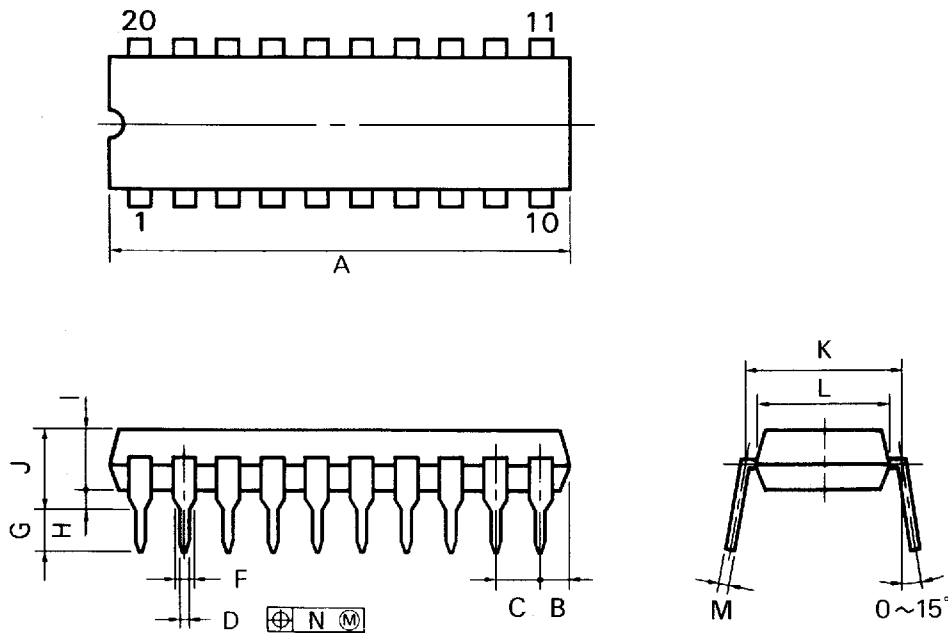

P20C-100-400B

NOTES

- 1) Each lead centerline is located within 0.25 mm (0.01 inch) of its true position (T.P.) at maximum material condition.
- 2) Item "K" to center of leads when formed parallel.

ITEM	MILLIMETERS	INCHES
A	27.94 MAX.	1.100 MAX.
B	2.54 MAX.	0.100 MAX.
C	2.54 (T.P.)	0.100 (T.P.)
D	0.50 <sup>+0.10</sup>	0.020 <sup>+0.004</sup> <sub>-0.005</sub>
F	1.2 MIN.	0.047 MIN.
G	3.5 <sup>±0.3</sup>	0.138 <sup>±0.012</sup>
H	0.51 MIN.	0.020 MIN.
I	4.31 MAX.	0.170 MAX.
J	5.72 MAX.	0.226 MAX.
K	10.16 (T.P.)	0.400 (T.P.)
L	8.6	0.339
M	0.25 <sup>+0.10</sup> <sub>-0.05</sub>	0.010 <sup>+0.004</sup> <sub>-0.003</sub>
N	0.25	0.01

**RECOMMENDED SOLDERING CONDITIONS**



The following conditions (see table below) must be met when soldering this product.

For more details, refer to our document "SEMICONDUCTOR DEVICE MOUNTING TECHNOLOGY MANUAL" (IEI-1207).

Please consult with our sales offices in case other soldering process is used, or in case soldering is done under different conditions.

**Type of Through Hole Device**

μPC1891ACY: 20 pin plastic DIP (400 mil)

Soldering Process	Soldering Conditions
Wave Soldering (For leads only)	Solder temperature: 260 °C or lower. Flow time: 10 seconds or less.
Partial Heating Method	Pin temperature: 260 °C or lower. Time: 10 seconds or less.

**Caution** Do not jet molten solder on the surface of package.